

Container for 3D-Bags

- ◆ Material: chromium nickel stainless steel 1.4301.
- ◆ Welds polished, stained surface
- ◆ Modular system (Trolley, Container, Lid; Stacking System)
- ◆ Different Bottom openings available
- ◆ Appropriate for clean room.

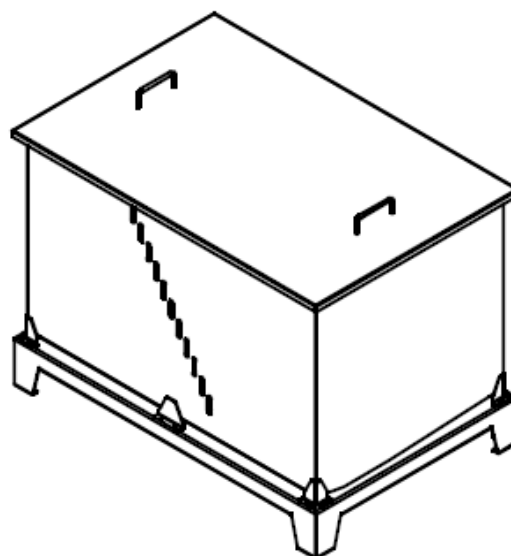

Description	Measuram. (LxWxH) mm	For Bag	Product-No.
Container 100 L / 200 L	800x600x720	100 L / 200 L	CCSS200L
Container 500 L	1200x800x870	500 L	CCSS500L
Container 1000 L	On request	1000 L	CCSS1000L
Lid for Container 100 L / 200L			CLSS200L
Lid for Container 500 L			CLSS500L
Lid for Container 1000 L			CLSS1000L
Trolley 100L / 200 L			CRSS200L
Trolley 500 L			CRSS500L
Trolley 1000 L			CRSS1000L
Stacking Kit 100 L / 200 L			CSKS200L
Stacking Kit 500 L			CSKS500L

Customized and shipping versions on request.